



TCA

S2

AUDIO MIXING CONSOLE

TECHNICAL MANUAL

S2 MIXING CONSOLE - PACKING

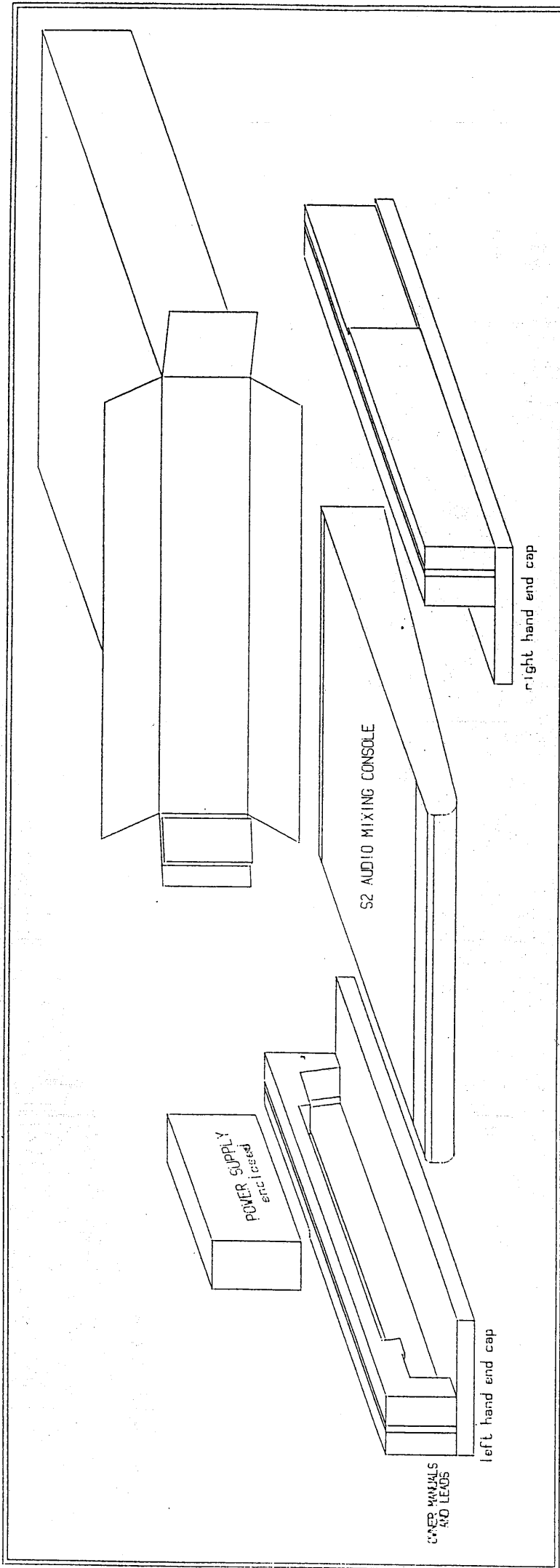

The above diagram shows the packing method for the S2

Should the mixer be repacked for shipment please ensure that it is packed as shown. Remember to enclose the mixer in the heavy duty polythene bag before fitting the polystyrene end caps. The power supply unit should be placed in the cardboard sleeve provided.

Please include this packing diagram in the polythene bag for future reference.

S2 MIXING CONSOLE - TECHNICAL MANUAL

This is the TECHNICAL MANUAL for the Thatched Cottage Audio S2 168 mixing console.

Included is the full set of drawings and information required to provide technical service back-up for this product.

For user information please refer to the S2 OWNER MANUAL supplied by Thatched Cottage Audio.

For information on the S2 EX8 expander unit please refer to the S2 EX8 TECHNICAL MANUAL (publication AP0121).

The S2 is designed and manufactured by ALLEN & HEATH in England for Thatched Cottage Audio.

SERVICE SUPPORT



Allen & Heath Publication AP0120 issue 1 Sept.1991 CD

L-R FAER - A1045
or A1015.

The S2 is an ultra compact professional recording mixer designed specifically to operate with the latest generation of multitrack tape machines and studio equipment.

Unheard of in its price range, the S2 includes full on board MIDI mute automation based on the most advanced and user-friendly V4 system. This provides automation of all channel, monitor and effects return mutes giving a creative freedom unique in mixers of this class.

The in-line format and versatile routing facilities allow up to 24-track recording and mixdown to two 2-track mastering machines without the need for re-patching.

The 16 channel S2 is easily expandable to a full 24 channels by adding on the EX8 extender unit.

Four dedicated stereo effects returns and the two signal paths per channel provide a maximum of 40 or 56 inputs with EQ available for mixdown.

The compact size and comprehensive facilities together with its superior audio performance, rugged yet stylish engineering, and low cost make the S2 the ideal choice for the small studio, mobile, or home recording situation.

KEY FEATURES:

Full V4 MIDI automation of channel, monitor and effects return mutes, using silent FET switching,

16-8-2 or 24-8-2 in-line formats,

8 groups, normalled to channel outputs 1-8, 9-16, 17-24,

Up to 56 inputs with EQ available for mixdown,

In-line monitoring,

Channel direct-to-tape switches allowing up to 24 tracks to be recorded simultaneously,

Separate EQ for channel and monitor paths, with EQ on switch,

6 aux busses providing effects and cue sends,

Dedicated stereo cue monitor output,

4 stereo effects returns with EQ, cue sends, and routing to all outputs,

Monitoring and record source switching for two 2-track mastering machines,

Dedicated stereo control room monitor output with switching for 2 pairs of loudspeakers,

LED bargraph metering, and separate channel peak LEDs,

Inserts on channels, groups and stereo mix,

Comprehensive monitor and talkback facilities,

2 frequency line-up oscillator,

Superior audio performance,

100mm faders and quality components used throughout,

Engineered for reliability.

16 channel version may be expanded to 24 channels.

CONSTRUCTION:

Single steel front panel and base plate with mediate side trims.

Large extruded aluminium armrest and rear plate.

Individual circuit assemblies connected by removable IDC harnesses for easy service access.

Separate MPS9 external power supply unit.

EX8 expander attaches on right hand side of 168 console to form a single piece 24 channel unit.

SPECIFICATION:

OPERATING LEVELS: Multitrack in/out -10dBV
2-track in/out -10dBV
Aux, cue out etc. 0dBu
Inserts 0dBu

FREQUENCY RESPONSE: 20Hz to 20kHz +0dB, -1dB

NOISE: Microphone EIN -127 dBu source = 150 ohm
LR Mix noise -78 dBu ref 0VU
Group mix noise -80 dBu ref 0VU

CROSSTALK: better than -80dB at 1kHz

DISTORTION: THD typically less than 0.01% at 1kHz
less than 0.02% at 10kHz

GAIN: Mic input variable from +10dB to +68dB
Line input variable from -10dB to +20dB
further +10dB available at each fader

MAXIMUM OUTPUT LEVEL: +21dBu

SIZE: 16-8 766mm x 725mm x 130mm
24-8 1036mm x 725mm x 130mm (expanded)

WEIGHT 16-8 Console 24 kg
MPS9 power supply 3 kg
Packed with MPS9 31 kg

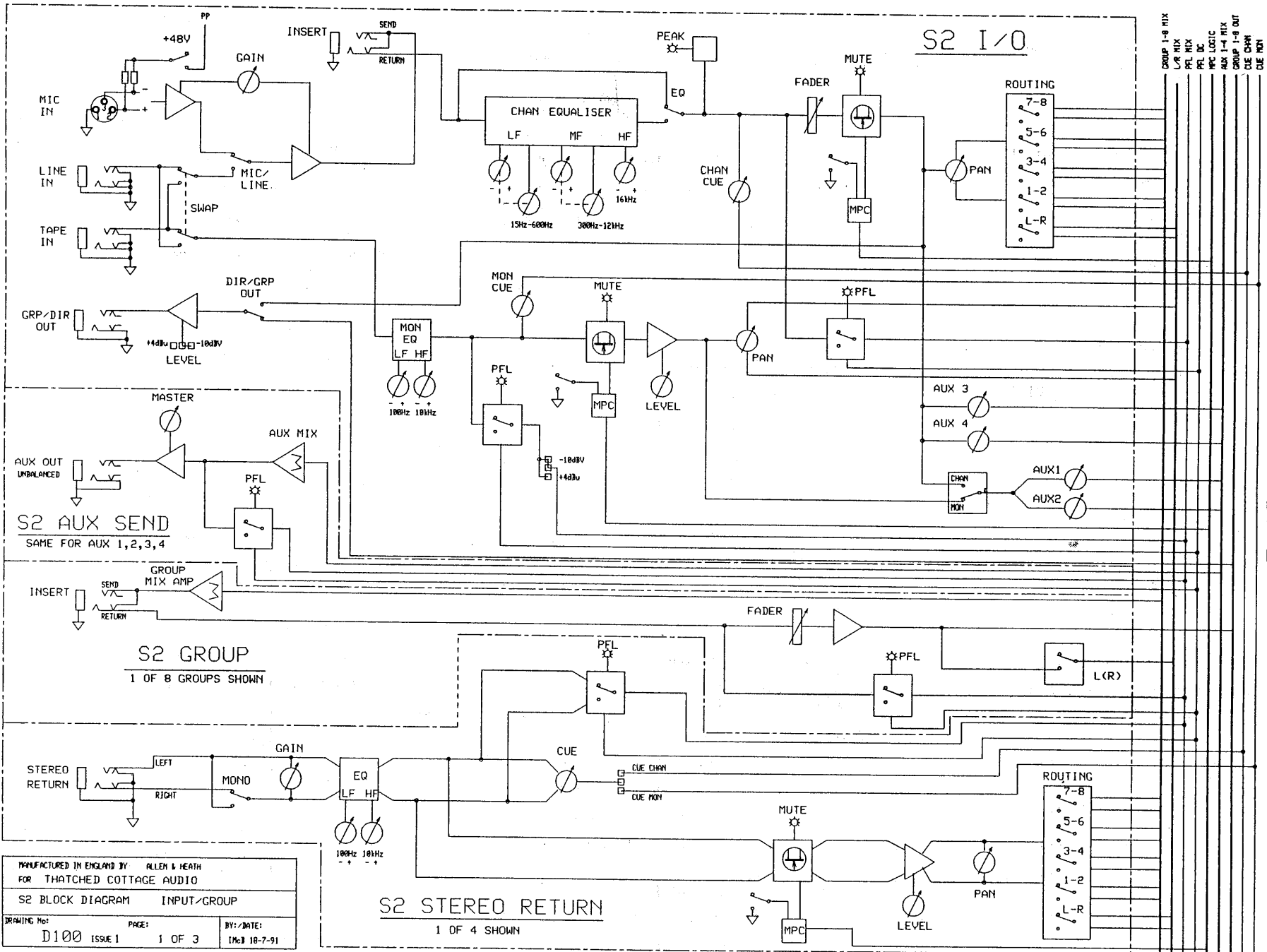

MANUFACTURED IN ENGLAND BY ALLEN & HEATH
FOR THATCHED COTTAGE AUDIO

S2 BLOCK DIAGRAM INPUT/GROUP

DRAWING No:	PAGE:	BY: / DATE:
D100 ISSUE 1	1 OF 3	IM: 18-7-91

CHANNEL (168 console and EX8 extender):

Microphone in - electronically balanced XLR
pin 2 = +

Line in - unbalanced 1/4" jack

Tape in and channel out - unbalanced 1/4" jack
Set for -10dBV operating level

Insert - 1/4" jack, tip = send, ring = return

+48V phantom power switch

CHANNEL PATH: Mic/line source switch

gain pot - wide ranging

Mic = +10 to +68 dB
Line = -10 to +20 dB

Aux 1 to 4 send pots (post-fader)

Chan cue send pot (pre-fader)

HF +/- pot 14dB 16kHz shelf
10dB at 10kHz

MF +/- pot 14dB
MF sweep pot 300Hz to 12kHz

LF +/- pot 14dB
LF sweep pot 15Hz to 600Hz

EQ on switch

Peak LED for Channel path

Pan pot

PFL switch + LED

Mute switch + LED

Direct/group output switch

Routing switches to L-R
1-2
3-4
5-6
7-8

100mm Fader - 10dB gain available

MONITOR PATH: Tape/line source reverse switch

mon cue send (pre-fader)

HF +/- 14dB 10kHz shelf
10dB at 8kHz

LF +/- 14dB 100Hz shelf
10dB at 100Hz

Level pot to L-R

Pan pot

PFL switch + LED

Mute switch + LED

Mon/chan Aux 1/2 select switch

GROUP:

Aux out - unbalanced 1/4" jack

Stereo return - 1/4" jack tip = left/mono
ring = right

Group insert - 1/4" jack tip = send
ring = return

Group bargraph meter - 10 bar rectangular LED

Aux send master pot

Aux master PFL switch + LED

STEREO RETURN: Mono source switch

Gain pot - -4dB to +14dB gain

HF +/- pot 14dB 10kHz shelf
LF +/- pot 14dB 100Hz shelf

Chan cue send (pre-level)

Routing switches to L-R
1-2
3-4
5-6
7-8

Pan pot

Level pot to L-R

PFL switch + LED

Mute switch + LED

GROUP SECTION: L-R switch (sub-group)

PFL switch + LED

100mm fader - 10dB gain available

MUTE PROCESSOR:

MIDI in, out and thru sockets - 5pin DIN

2-digit 7-segment display

Shift switch + LED
Toggle switch + LED
record switch + LED
clear switch + LED

Update switch

Up switch

Down switch

Recall switch

MASTER:

Control room main output L&R - unbalanced 1/4" jack

Control room alt output - 1/4" jack tip = L
ring = R

2-track tape in (x2) - 1/4" jack tip = L
ring = R

2-track tape out (x2) - 1/4" jack tip = L
ring = R

L&R inserts - 1/4" jack tip = send
ring = return

Stereo cue out - 1/4" jack tip = L
ring = R

Chan cue out - unbalanced 1/4" jack

Mon cue out - unbalanced 1/4" jack

DC input - 5pin XLR - connect to MPS9 power supply

Oscillator: 10kHz/1kHz switch

Level pot

Osc to groups switch

Cue master pot - controls both chan and mon cue

STEREO CUE: Source switches - mon cue
chan cue
L-R
monitor source
(tape 1/2, L-R)

Level pot

PFL switch + LED

2-TRACK: Tape 1 source switch - L-R or tape 2
Tape 2 source switch - L-R or tape 1

CONTROL ROOM: Source switches - all up = L-R
Tape 1
Tape 2

PFL active LED

Mono switch

Alt/main speaker select switch

Level pot

Mute switch

TALKBACK: Level pot

Talk to cue switch (non-latching)
Talk to groups switch (non-latching)

100mm L-R fader - 10dB gain available

Headphones jack - 1/4" jack tip = L
ring = R

-BUS-

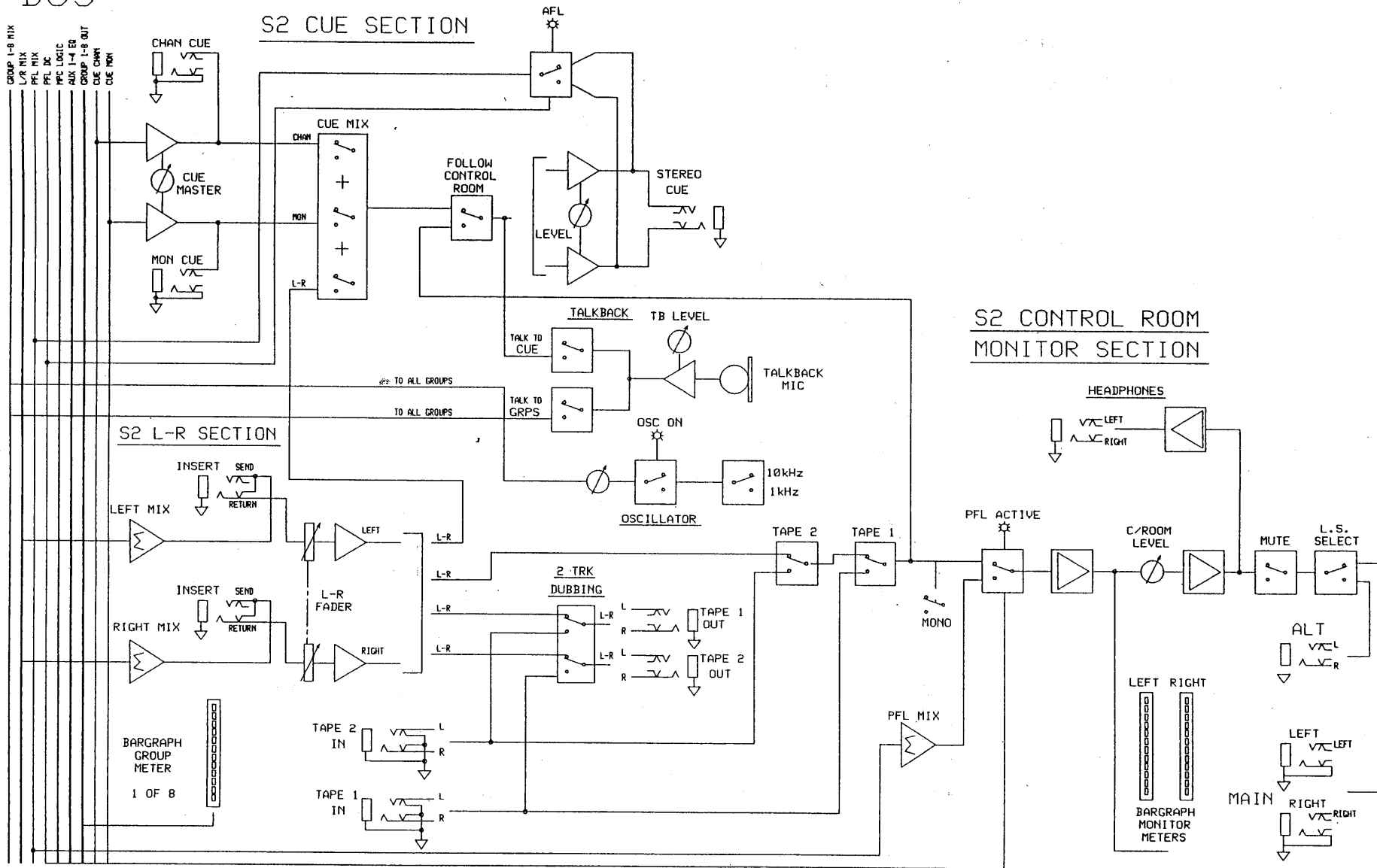

MANUFACTURED IN ENGLAND BY ALLEN & HEATH FOR THATCHED COTTAGE AUDIO		
S2 BLOCK DIAGRAM L-R & MASTER		
DRAWING No: D100	PAGE: 2 OF 3	BY: / DATE: JMcB 19-7-91

S2 I/O MUTE PROCESSOR

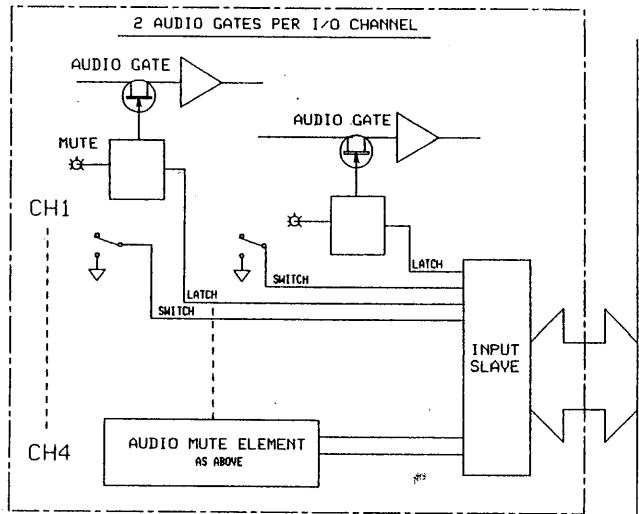

CH5
IDENTICAL TO S2 BLOCK SHOWN ABOVE
CH24

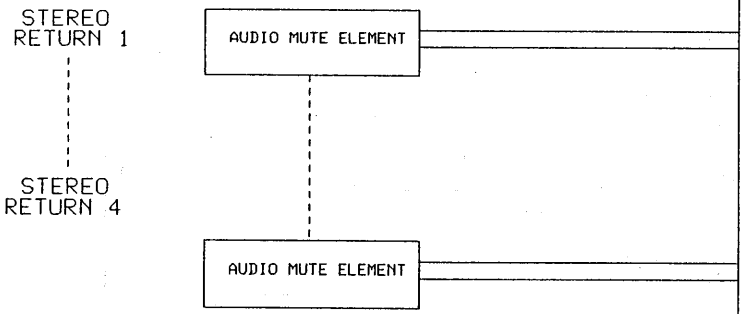

MPC BUSS

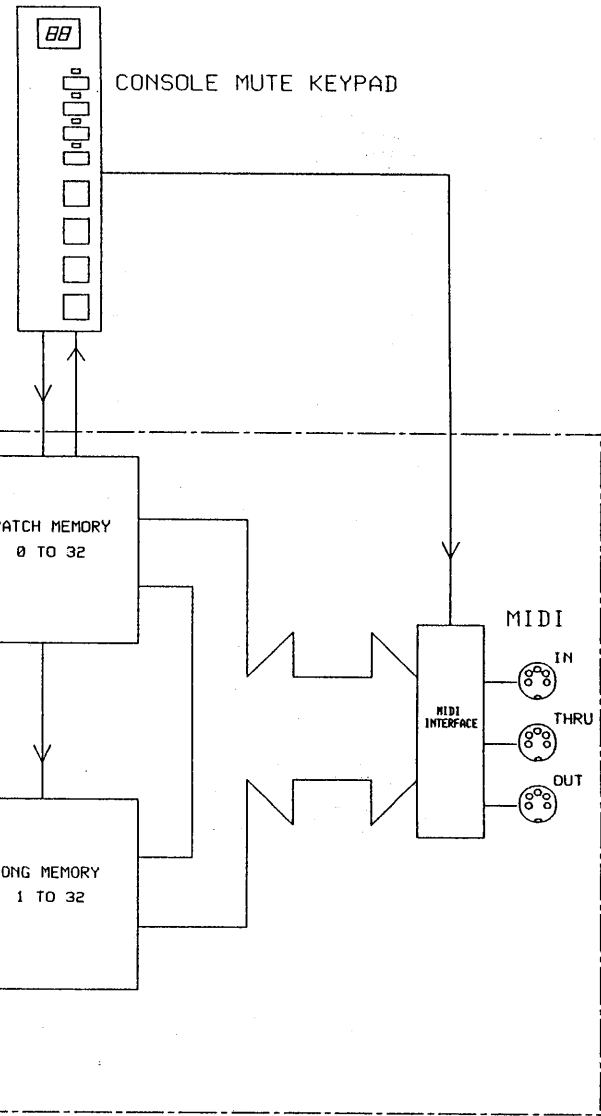

S2 MASTER MUTE PROCESSOR

V4 SYSTEM

MANUFACTURED IN ENGLAND BY ALLEN & HEATH		
FOR THATCHED COTTAGE AUDIO		
S2 BLOCK DIAGRAM		MUTE AUTOMATION
DRAWING No:	PAGE:	BY-/DATE:
D100	ISSUE 1 3 OF 3	16th 19-7-91

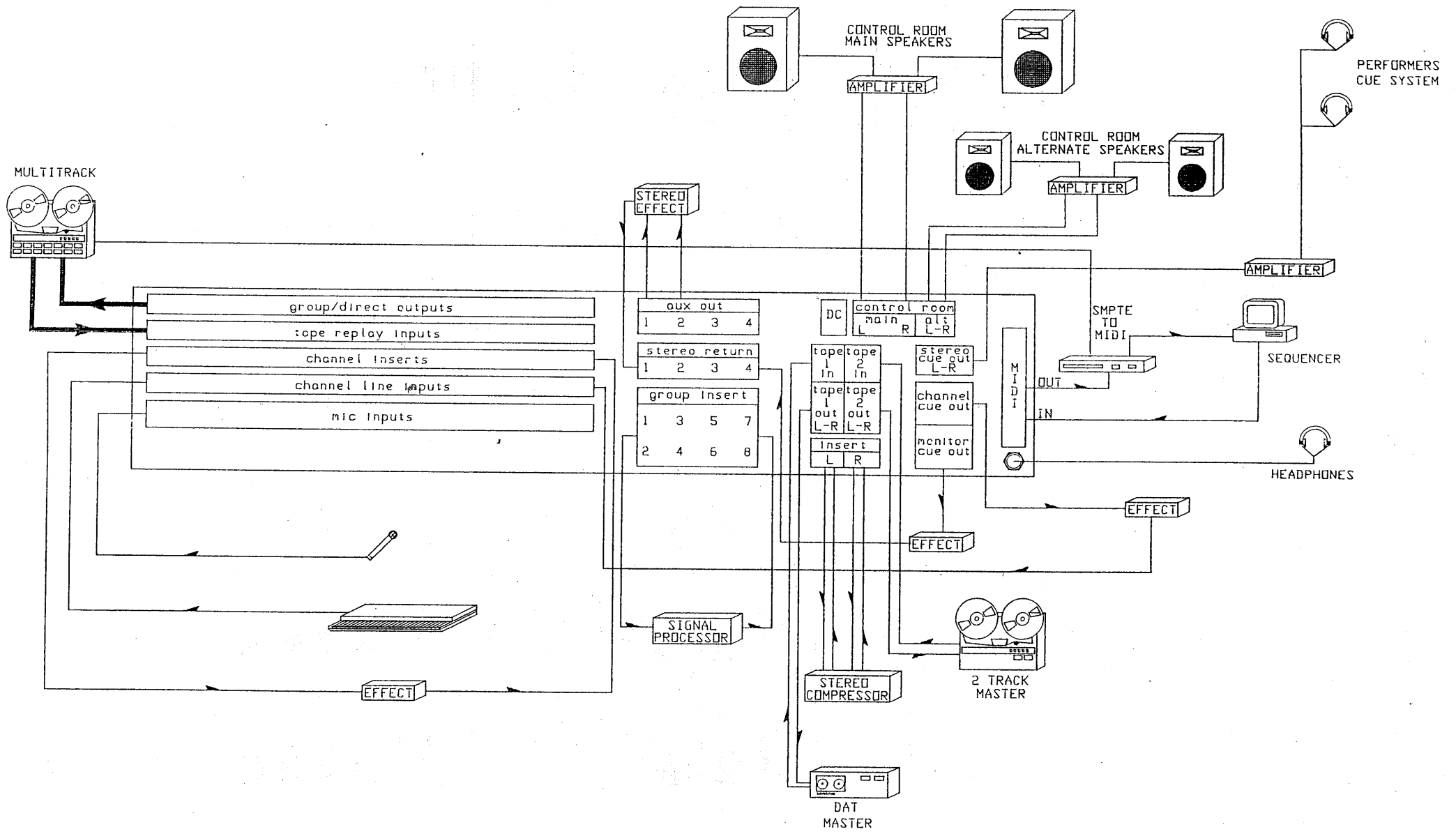

ISSUE	REVISION	BY	DATE
1	ORIGIN	IMcB	24-7-91

DRAWING TITLE
S2 AUDIO MULTITRACK SYSTEM
 INSTALLATION

MANUFACTURED IN ENGLAND BY ALLEN & HEATH
 FOR THATCHED COTTAGE AUDIO
 DRAWING No. **D101** ISSUE **1**

grpB/dir out

16

tape in

chan insert

line in

mic

aux out

1 2 3 4

stereo return

1 2 3 4

group insert

1 3 5 7

2 4 6 8

control room

main R alt

S/No

2 trk tape

in 1 2

stereo cue

out

chan thru

cue out

in

mon MIDI

D.C. input

mono sig

stereo left right

insert send ret

XLR pin 2 = +

+48v

line mic

gain

rev line tape

mon cue

HF 10kHz

LF 100Hz

lev

pan

pfl

mute

mon chan

aux 1

2

chan aux 3

4

Chan Cue

3 4 5 6 7 8 9 10

HF 15kHz

MF

300Hz 12kHz

LF 15Hz 600Hz

EQ

1 2 3 4 5 6 7 8

+6 +3 0 -1 -3 -6 -10 -15 -20

group meters

L R

+6 +3 0 -1 -3 -6 -10 -15 -20

monitor

S2

with MIDI mute automation

aux masters

aux 1 2 3 4

gain

HF 10kHz

LF 100Hz

chan cue

L-R

1-2 3-4 5-6 7-8

pan

lev

pfl

mute

1 2 3 4

lev

osc

osc to groups

cue master

mon cue + chan cue + L-R

follow c/room

lev

stereo cue

afl

2 trk dubbing

1 tape 2 > tape 1

2 tape 1 > tape 2

L-R

2 trk tape

pfl active

mono

L.S. select alt main

lev

control room

shift

toggle

record

clear

update

recall

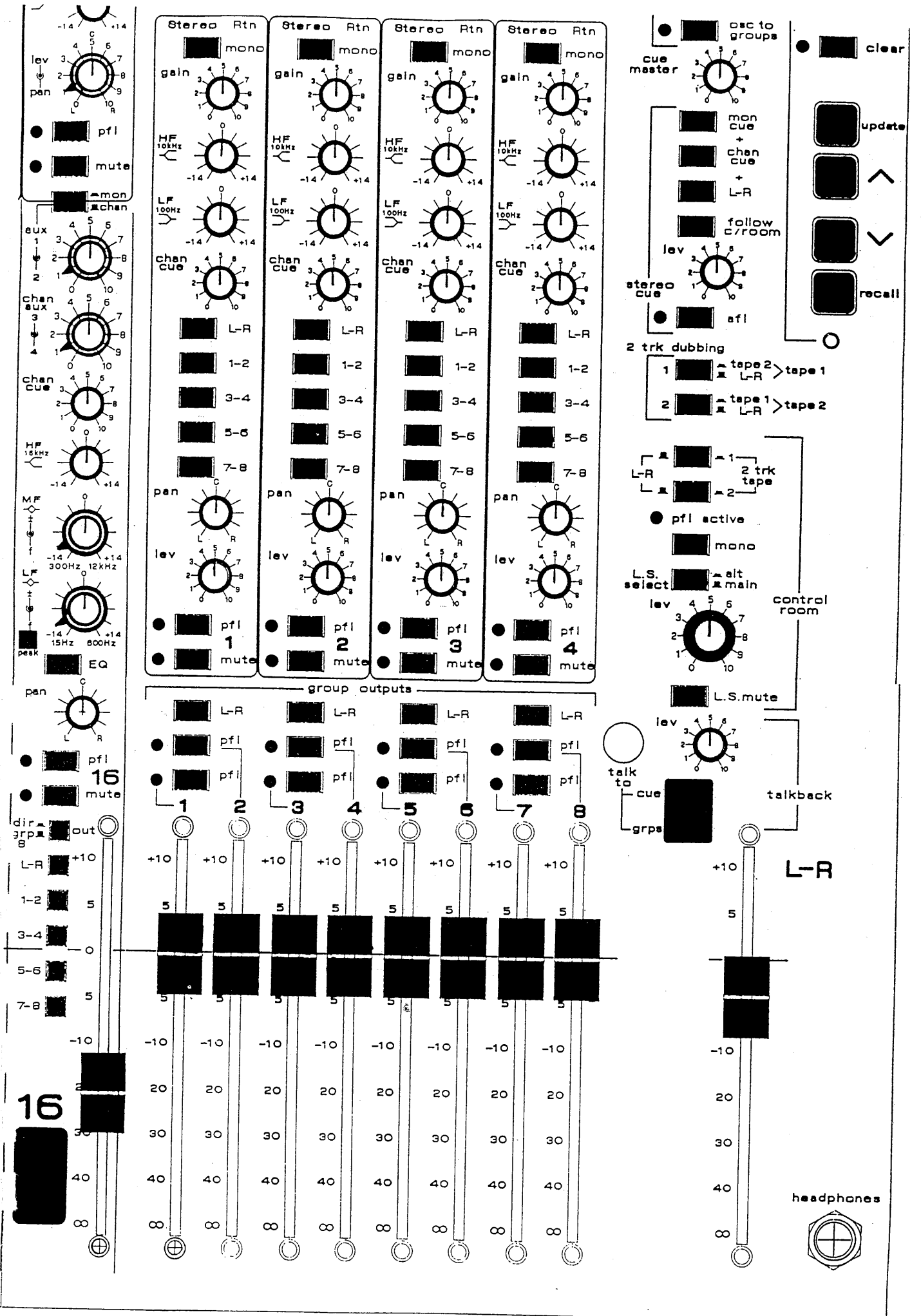

POWER SUPPLY

MPS9
ZS700-711 (240V)
ZS700-712 (110V)

16:8 CHASSIS ZX000-009 1

BASE	AA1122 D091/2	AA1123 D103/1
EXTRUSION	AA1120 D085/3	AA1121 D085/3
SIDE TRIM	AA1126L+R D092/2	

4-JACK PCB
ZX000-007
AG0307/2
FV029/2
CCT D090/1
7

METER PCB
ZX000-004
AG0304/1
FV026/1
CCT D087/1
1

METER HARNESS
ZX000-016
D097/2
1

EX8 CHASSIS ZX000-011 1

HARNESS ASSEMBLIES.

MAIN	SLAVE
ZX000-012 D095/2	ZX000-013 D096/2

16:8

16:8 PANEL COMPLETE
ZX000-601
S2 MIXING CONSOLE
(CHANNELS 1 TO 16)

EX8 PANEL COMPLETE
ZX000-602
EXTENDER
(CH 17 TO 24)

EX8 F/PANEL
AA1125
D102/1
EV011/1

EX8 PANEL ASSY
ZX000-010

HARNESS ASSEMBLIES.

MAIN	SLAVE
ZX000-014 D104/1	ZX000-015 D105/1

EX8

16:8 PANEL ASSY
ZX000-008
1

16:8 F/PANEL
AA1124
D086/3
EV009A+B/2

SLAVE PCB
ZX000-006
AG0306/2
FV028/2
CCT D089/1
5

ID PCB
ZX000-001
AG0301/2
FV023/2
CCT D082/2
16

GROUP PCB
ZX000-002
AG0302/2
FV024/2
CCT D083/1
4

MASTER PCB
ZX000-003
AG0303/2
FV025/2
CCT D084/1
1

MICRO PCB
ZX000-005
AG0305/2
FV027/2
CCT D088/1
1

SLAVE PCB
ZX000-006
AG0306/2
FV028/2
CCT D089/1
2

ID PCB
ZX000-001
AG0301/2
FV023/2
CCT D082/2
8

THE EX8 EXTENDER UNIT MAY BE RETRO-FITTED TO THE S2 TO CONVERT IT TO 24 CHANNELS.

ISSUE	REVISION	BY	DATE
A	ORIGIN		CD 11-5-91
3	PRODUCTION		14:8 29-8-91

FORMATTED ASSEMBLIES

	16-8	ZZ-S2-001	110V 240V /1 /2
	EX8	ZZ-S2-002	

PRODUCT NAME = S2
PRODUCT GROUP = 57
COMPLETE ASSEMBLIES = ZX000-601 ETC
SUB ASSEMBLIES = ZX000-001 ETC

DRAWING TITLE
S2 PARTS STRUCTURE

MANUFACTURED IN ENGLAND BY ALLEN & HEATH
FOR THATCHED COTTAGE AUDIO

DRAWING No. D093 ISSUE 3

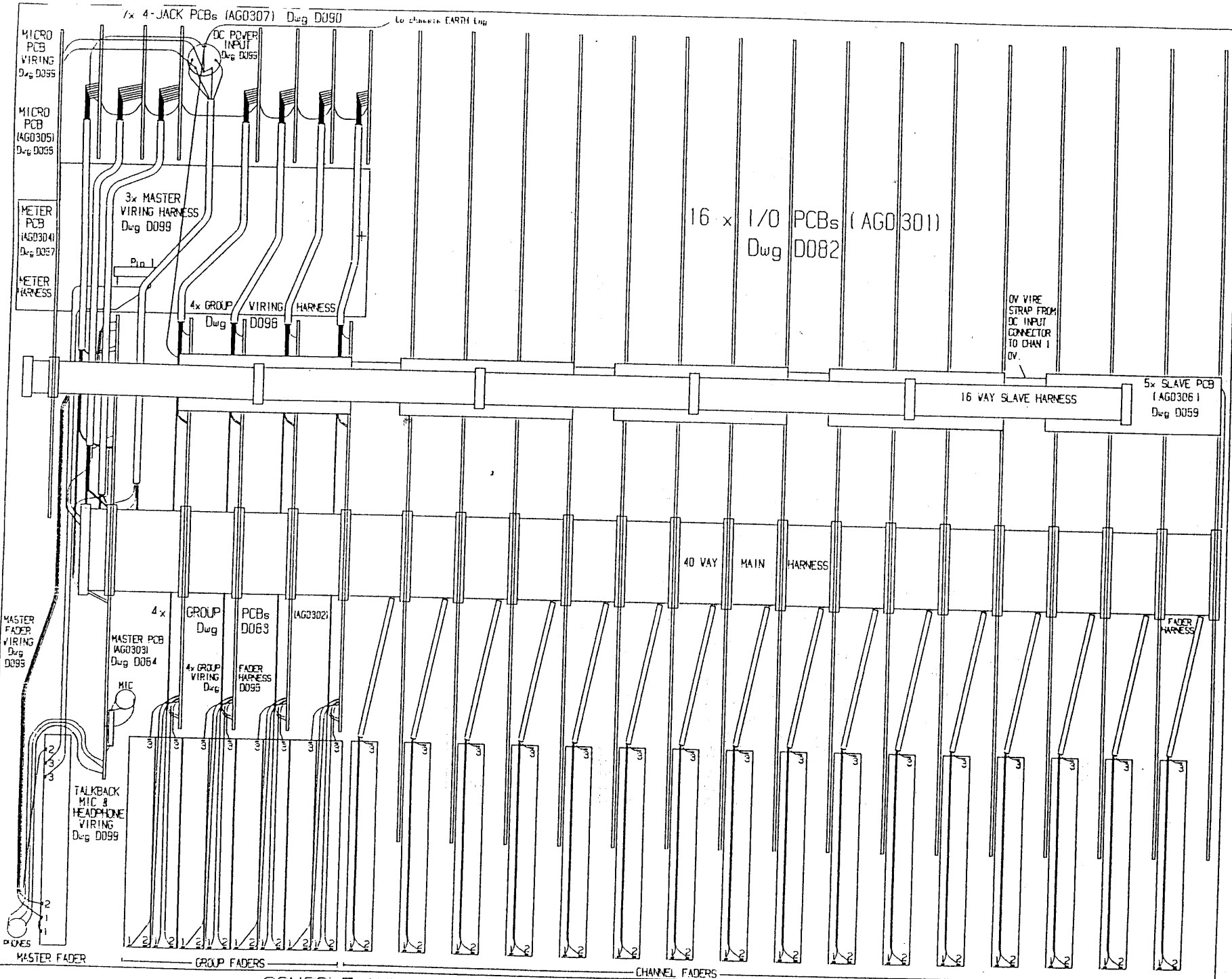

CONSOLE INVERTED WITH CHASSIS BASE REMOVED.

S2 INTERNAL LAYOUT	
Dwg.	D106 Issue 1
By:	IMcB 10-9-91

S2 SERVICE ACCESS

Normal operation of the S2 mixing console does not require internal access for option setting or adjustment. Internal assignments and adjustments are preset by the factory or carried out by an appointed service agent.

ALL SERVICE WORK THAT REQUIRES REMOVAL OF THE BASE SHOULD BE REFERRED TO QUALIFIED SERVICE PERSONNEL ONLY.

PROCEDURE:

1. Disconnect the power supply and all leads from the console.
2. Place the console upside down on a suitable flat surface. Prevent damage to the knobs and control panel.
3. Remove the front and rear base screws and lift off the base. It may be necessary to loosen the M6 side trim screws slightly first.
4. It should not normally be necessary to remove the side trim or front/rear extrusions fully. Access to all circuit assemblies is possible with these items in place.
5. Carry out the work required.
6. Check accuracy of work and connector alignment before replacing the base. Remove all solder debris etc. Ensure correct seating of the circuit assemblies and wiring harnesses.
7. Refit the base and tighten the side trim screws.
8. Reconnect the power and leads and test for correct operation.

S2 HIGH LEVEL MULTITRACK OPTION

The S2 is factory preset for operation with low level (-10dBV) multitrack tape machines.

It may be internally reconfigured for operation with high level (+4dBu) multitrack tape machines.

Two link changes on each of the channel (IO) pcbs is required. This sets the GRP/DIR OUT and MONITOR PFL sensitivity for high level.

This option is shown in BLOCK DIAGRAM D100 page 1.

The circuit details and link positions are shown in IO CIRCUIT DIAGRAM D082 and PCB LAYOUT FW023D.

PROCEDURE:

1. Place mixer upside down on flat surface.
2. Remove front and rear screws and remove base.
3. Unplug main 40way IDC harness and identify option links J3 and J4.
4. Desolder and remove PFL link J3.
5. Resolder OUTPUT link J4 to HI position.
6. Plug on harness and refit base.
7. Test for correct operation.

NOTES:

1. Different settings of the CHANNEL GAIN and MONITOR LEVEL controls are required. Adjust for correct level using PFL.
2. This option affects only the multitrack tape level. The 2-track tape connection is set for low level (-10dBV) and may not be changed. Most 2-track machines have sensitivity controls to allow operation with low level equipment.
3. Carry out change to EX8 expander channels if required ie. for 24 track multitrack machines.
4. **THIS WORK SHOULD ONLY BE CARRIED OUT BY QUALIFIED SERVICE PERSONNEL.**

GROUP PCB AG0302

PCB COMPONENT VIEWS

4JACK PCB AG0307

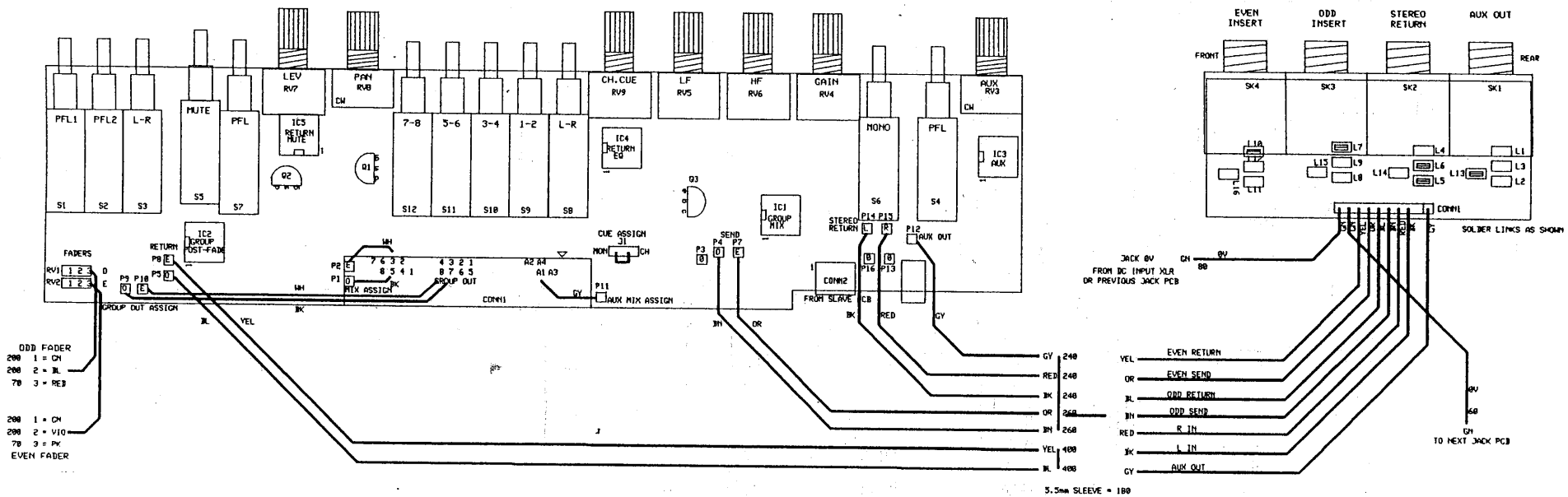

S2 GROUP WIRING HARNESS

DRAWING No. D098 issue 2 BY CD 30-8-91

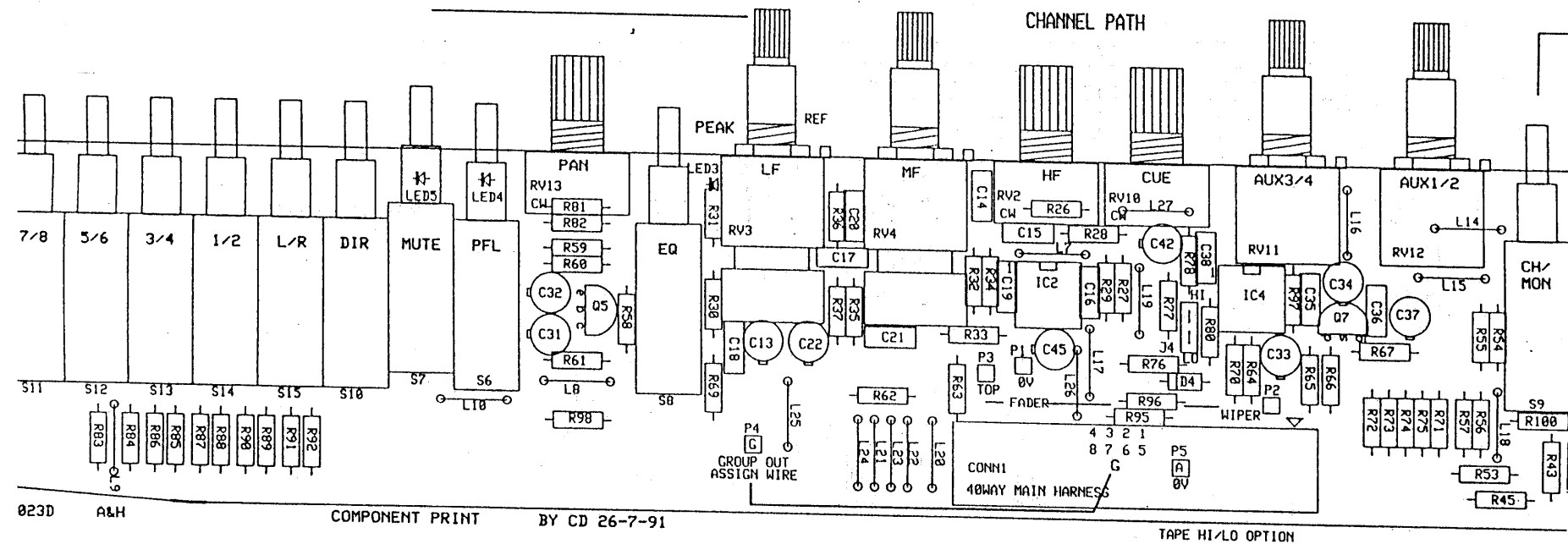
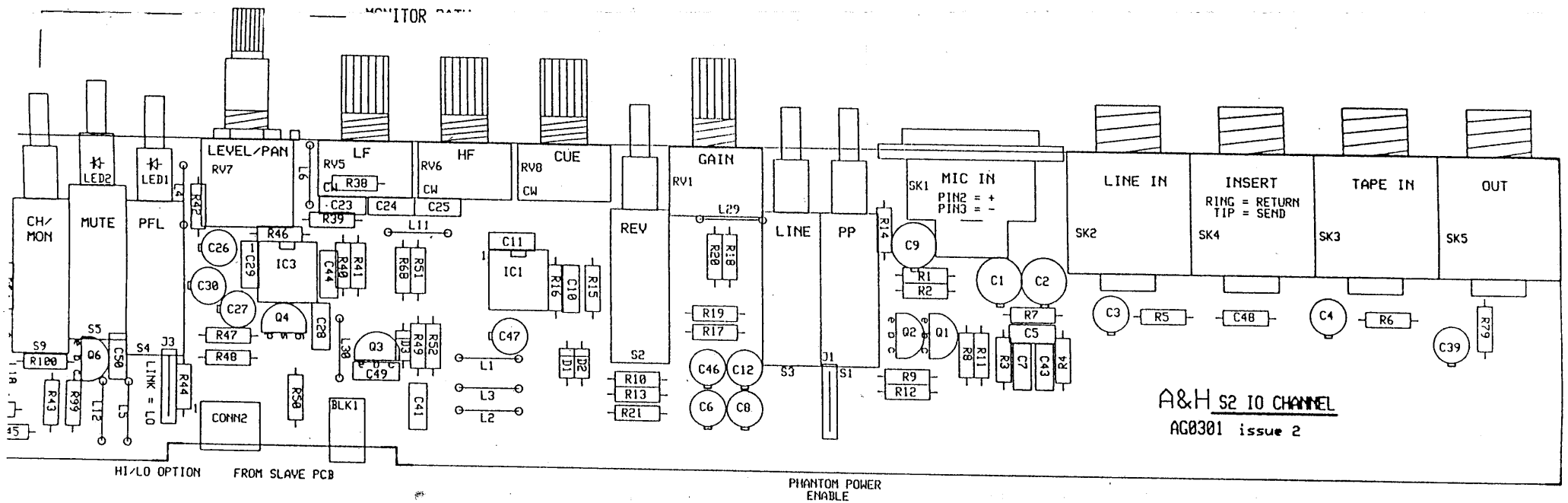

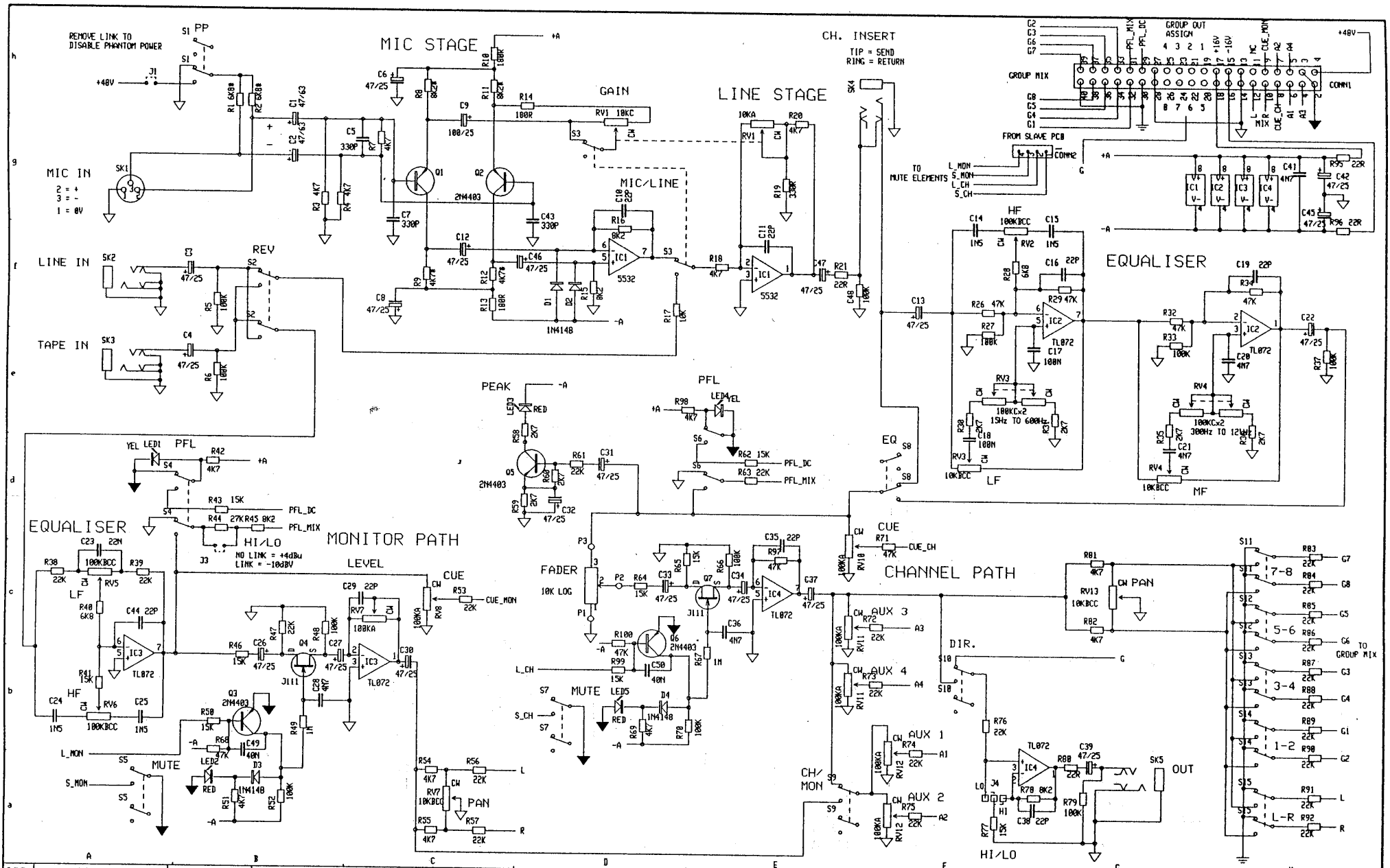

ISS.	REVISION	BY	DATE	NOTES	UNIT TITLE	MANUFACTURED IN ENGLAND BY ALLEN & HEATH
1	ORIGIN	CD	26-3-91	1. RESISTORS MARKED * ARE 1% ALL OTHERS ARE 5% 1/4W UNLESS OTHERWISE MARKED	S2	FOR THATCHED COTTAGE AUDIO
2	PRODUCTION (REVISED PRE-APP)	CD	8-7-91	2. ELECTROLYTIC CAPACITORS ARE µF/VOLTS		
					DRAWING TITLE	DRAWING No.
					IO CIRCUIT DIAGRAM	D082 ISSUE 2
					PCB TYPE AG0301	

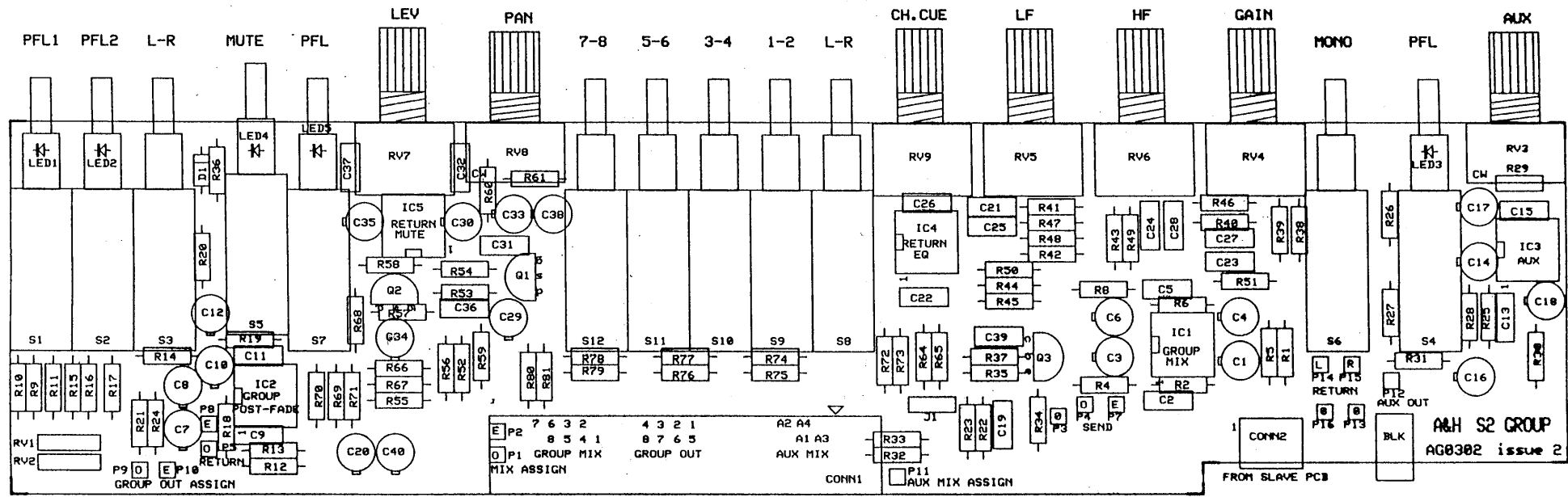

FW024D

COMPONENT PRINT

BY CD 4-8-91

A&H

CONN2 FROM SLAVE PCB
 BLK A&H S2 GROUP
 AG0302 issue 2

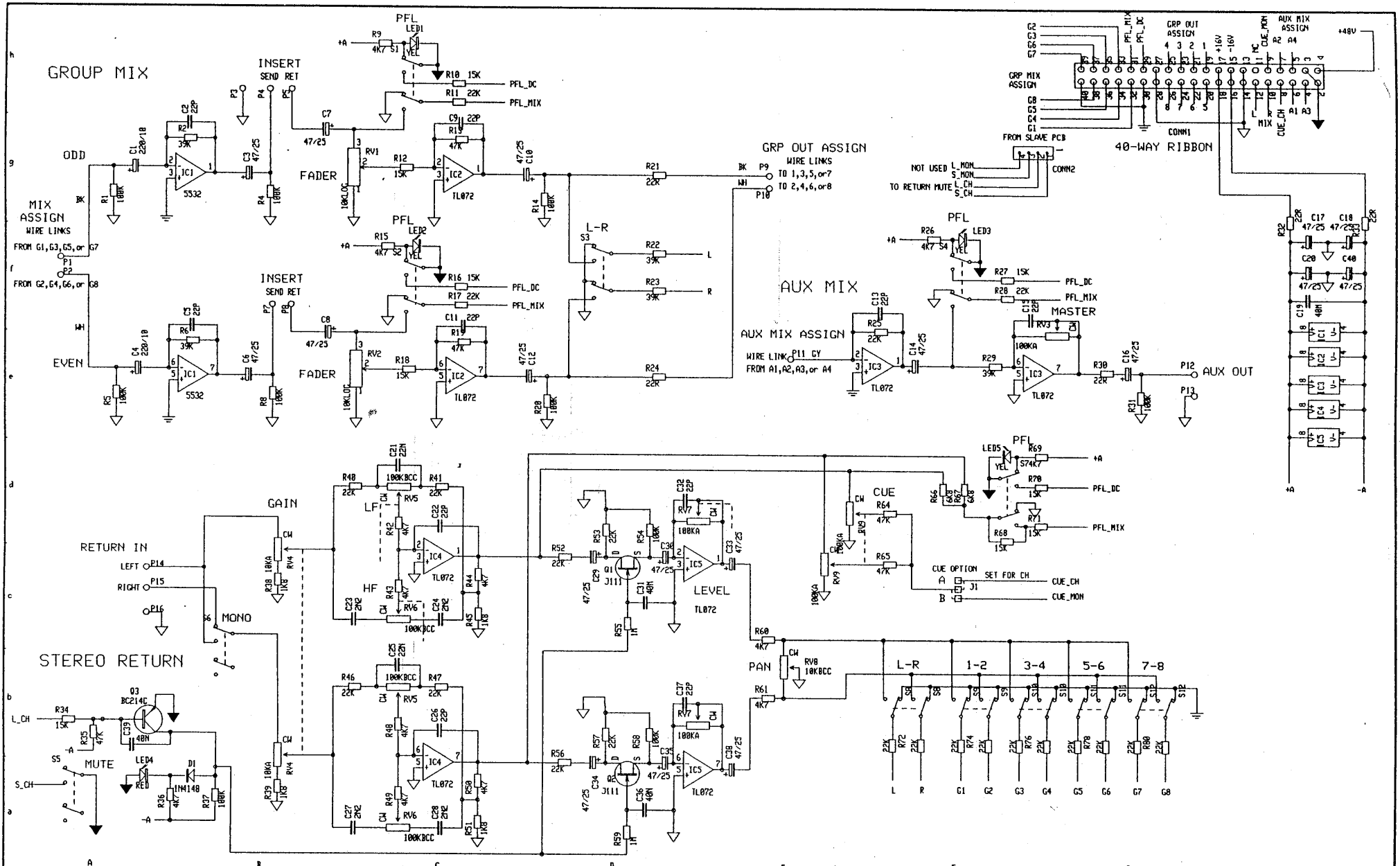

ISS.	REVISION	BY DATE	NOTES	UNIT TITLE	
1	ORIGIN PRODUCTION	CD 2-4-91	1. RESISTORS MARKED * ARE 1% ALL OTHERS ARE 5% 1/4W UNLESS OTHERWISE MARKED 2. ELECTROLYTIC CAPACITORS ARE µF/VOLTS	S2	MANUFACTURED IN ENGLAND BY ALLEN & HEATH
				GROUP CIRCUIT DIAGRAM	FOR THATCHED COTTAGE AUDIO
				PCB TYPE AG0302	DRAWING No. D083 ISSUE 1

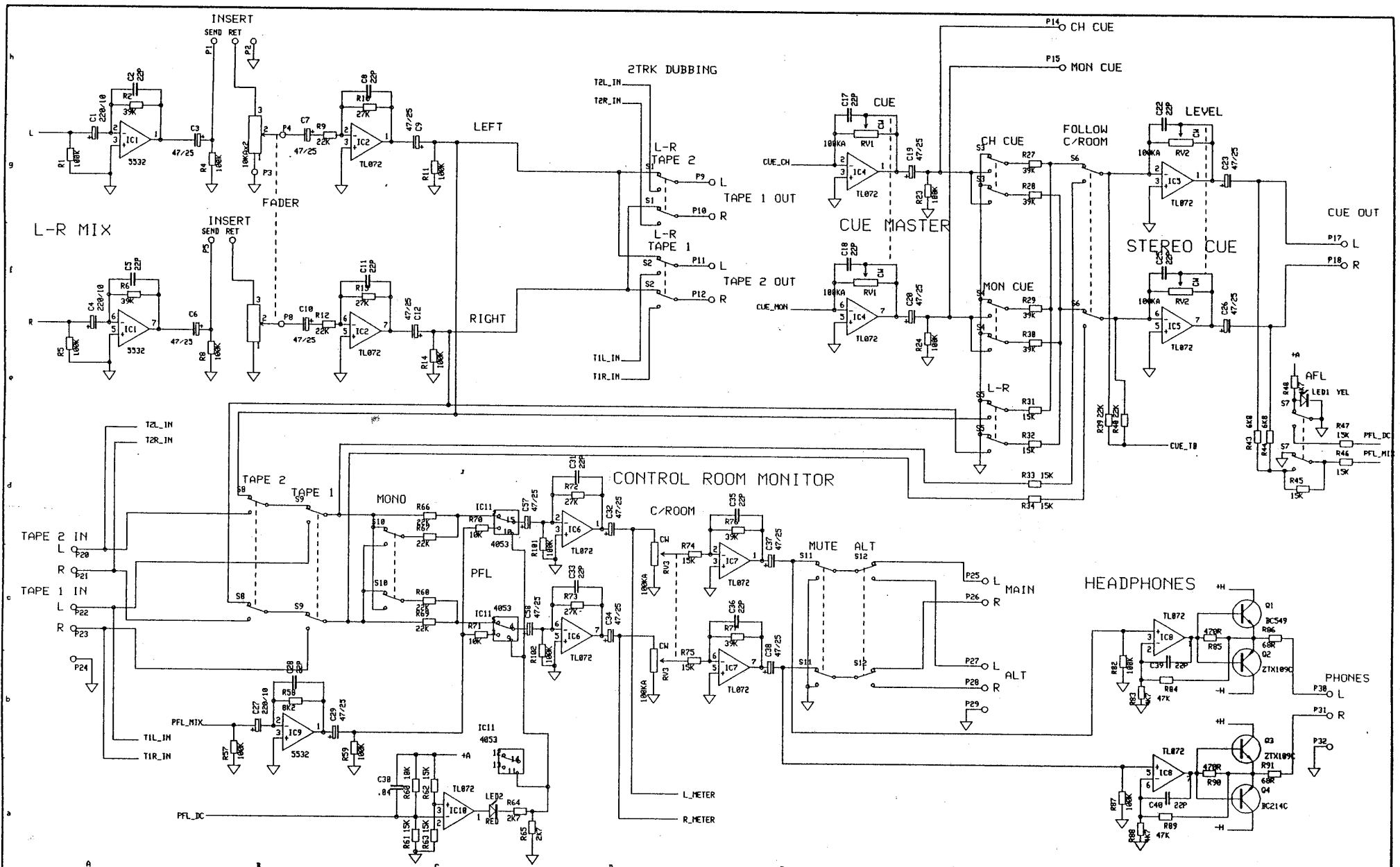

ISS.	REVISION	BY DATE	NOTES	UNIT TITLE	MANUFACTURED IN ENGLAND BY ALLEN & HEATH
1	ORIGIN PRODUCTION	CD 4-4-91	1. RESISTORS MARKED # ARE 1% ALL OTHERS ARE 5% 1/4W UNLESS OTHERWISE MARKED 2. ELECTROLYTIC CAPACITORS ARE 50V VOLTS	S2	FOR THATCHED COTTAGE AUDIO
				DRAWING TITLE	DRAWING No. D084 ISSUE 1
				SHEET 1 OF 2	
				MASTER CIRCUIT DIAGRAM	
				PCB TYPE AG0303	

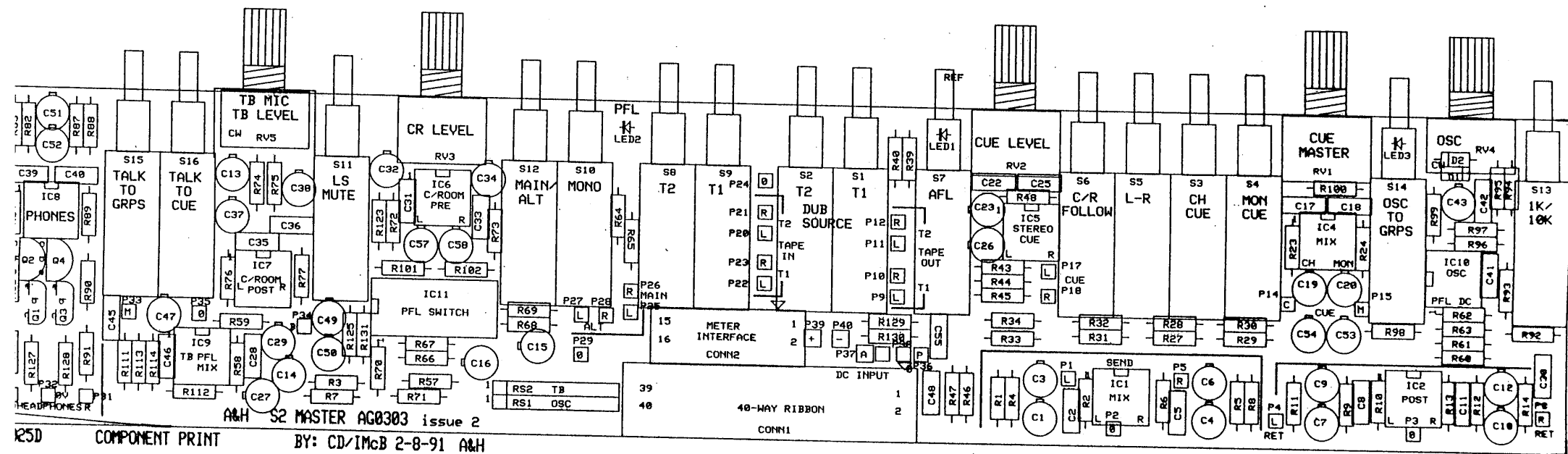

A&H S2 MASTER AG0303 issue 2

R25D COMPONENT PRINT BY: CD/IMCB 2-8-91 A&H

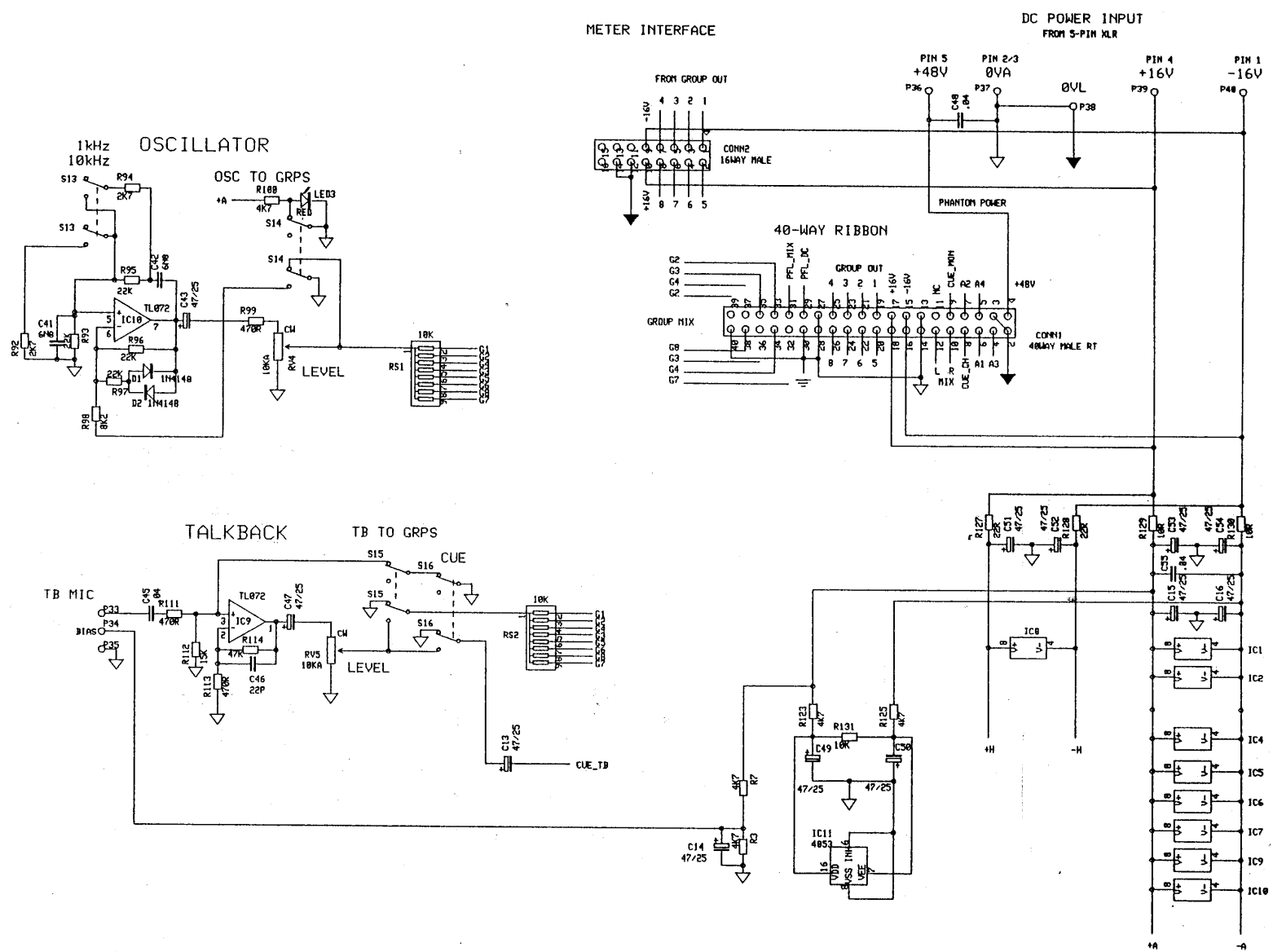

ISS.	REVISION	BY DATE
1	ORIGIN PRODUCTION	CD 4-4-91

NOTES

- RESISTORS MARKED # ARE 1% ALL OTHERS ARE 5% 1/4W UNLESS OTHERWISE MARKED
- ELECTROLYTIC CAPACITORS ARE μ F/VOLTS

UNIT TITLE
S2

DRAWING TITLE
SHEET 2 OF 2
MASTER CIRCUIT DIAGRAM
PCB TYPE AG0303

MANUFACTURED IN ENGLAND BY ALLEN & HEATH

FOR THATCHED COTTAGE AUDIO

DRAWING No. D084 ISSUE 1

G

LR

M

REAR

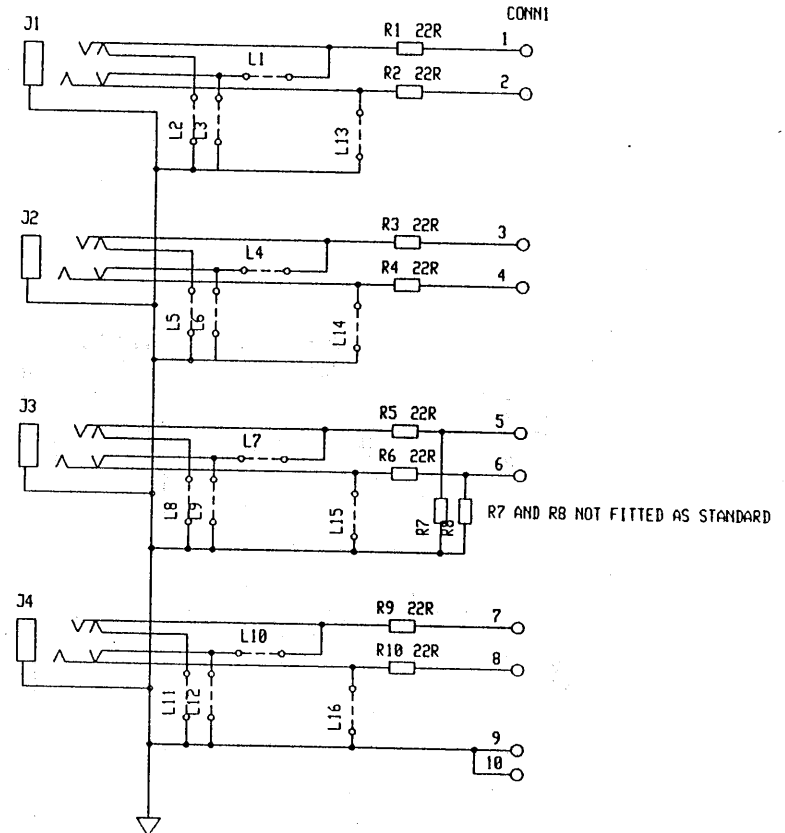
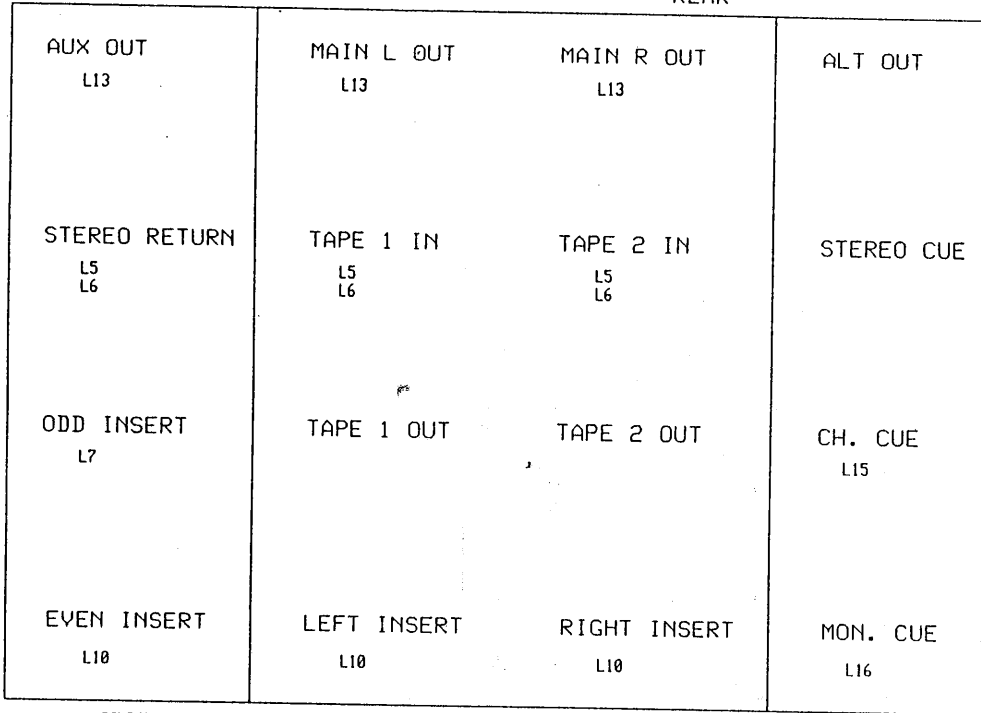

SOLDER LINK OPTIONS ACCORDING TO PCB POSITION

FRONT

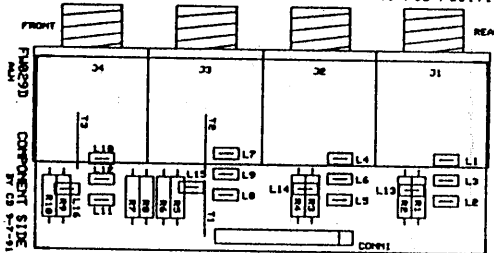

A&H S2 4-JACK AC8387 Issue 2

REVISION	BY	DATE
ISS.1	ORIGIN	PRODUCTION CD 22-4-91

UNIT TITLE	S2
DRAWING TITLE	4-JACK CIRCUIT DIAGRAM
	PCB TYPE AG0307

MANUFACTURED IN ENGLAND BY ALLEN & HEATH FOR THATCHED COTTAGE AUDIO
DRAWING No. D090 ISSUE 1

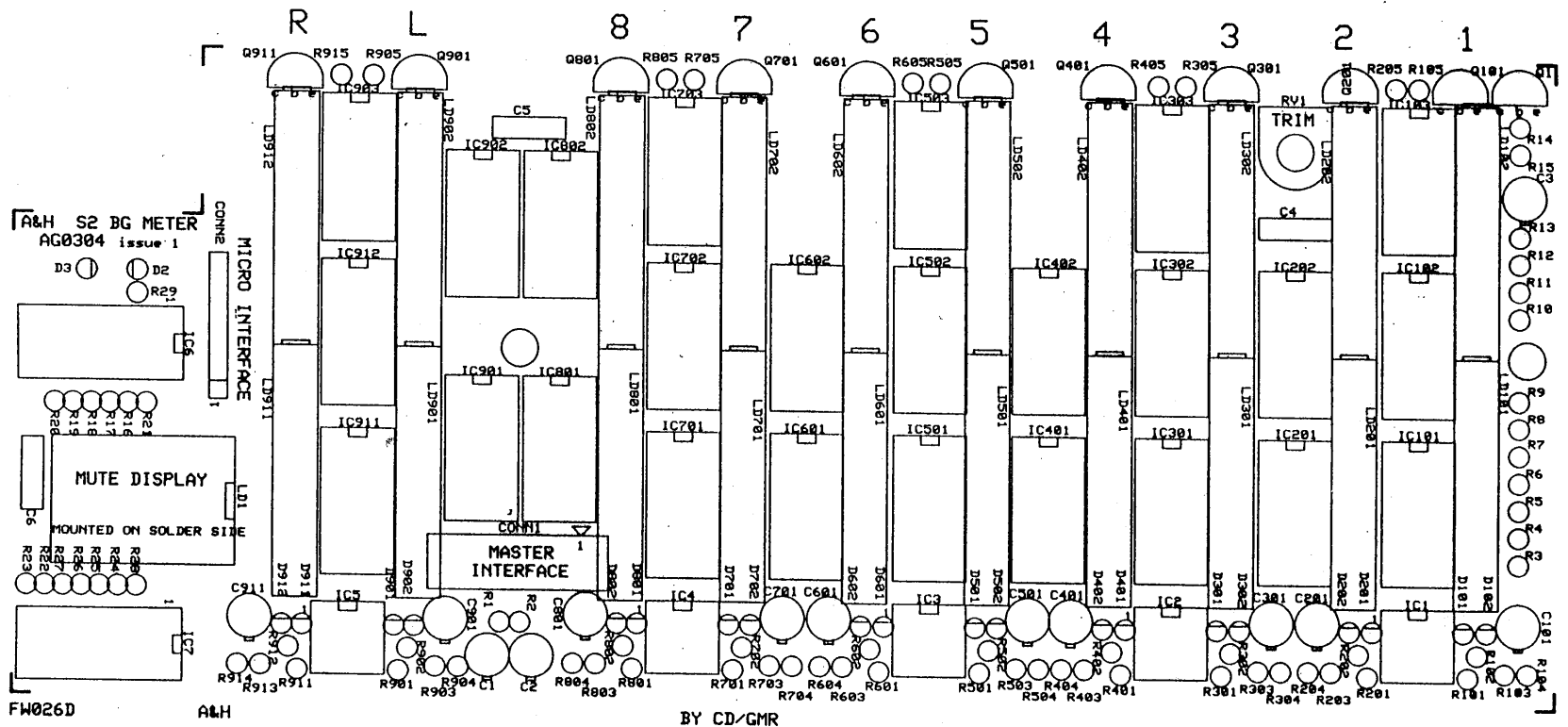

FW026D

A&H

BY CD/GMR

A&H S2 BG METER
AG0304 Issue 1

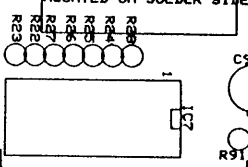
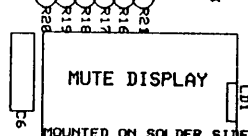
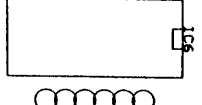
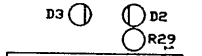

MOUNTED ON SOLDER SIDE

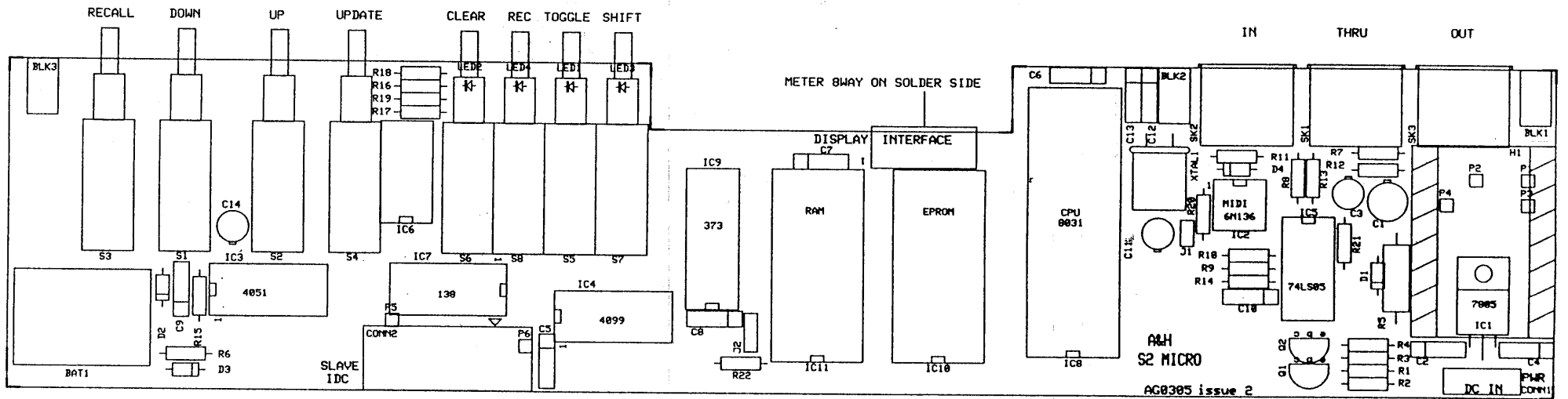

ALH

AG0305 issue 2
 COMPONENT PRINT

BY CD 36-7-91

FW027D

MUTE PROCESSOR DISPLAY

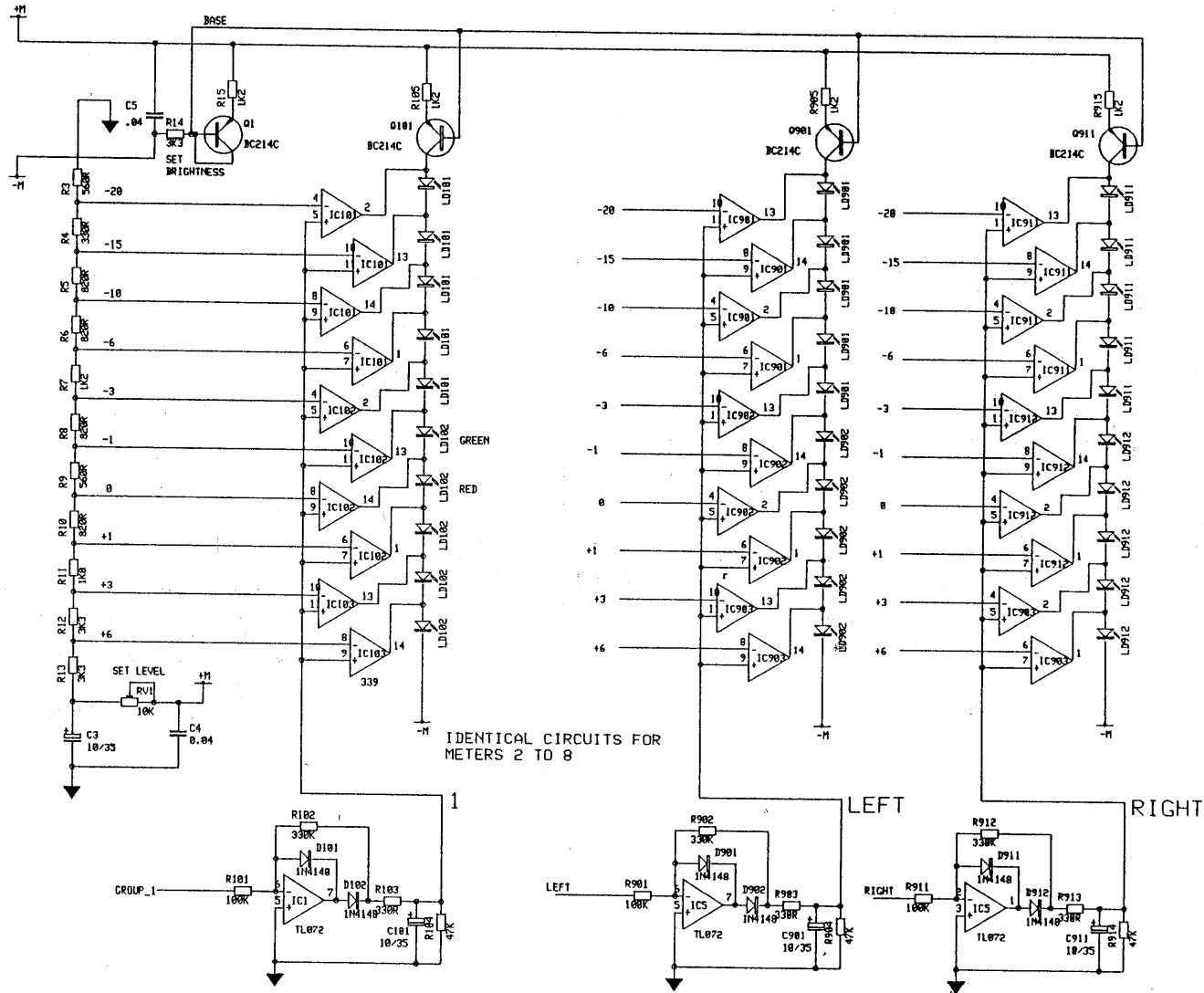
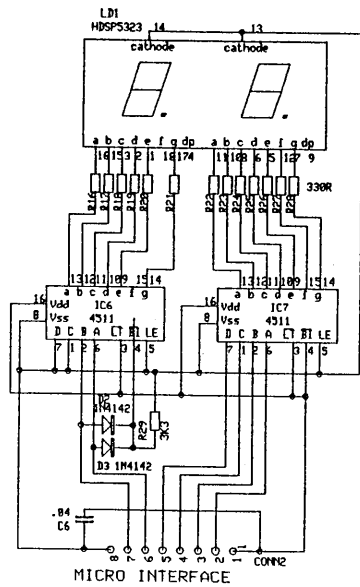

ISS.	REVISION	BY DATE	NOTES	UNIT TITLE	MANUFACTURED IN ENGLAND BY ALLEN & HEATH
1	ORIGIN PRODUCTION	CD 16-4-91	1. RESISTORS MARKED # ARE 1% ALL OTHERS ARE 5% 1/4W UNLESS OTHERWISE MARKED 2. ELECTROLYTIC CAPACITORS ARE µF/VOLTS	S2	FOR THATCHED COTTAGE AUDIO
				DRAWING TITLE	DRAWING No. D087 ISSUE 1
				BARGRAPH METER CIRCUIT	
				PER TYPE AG0304	

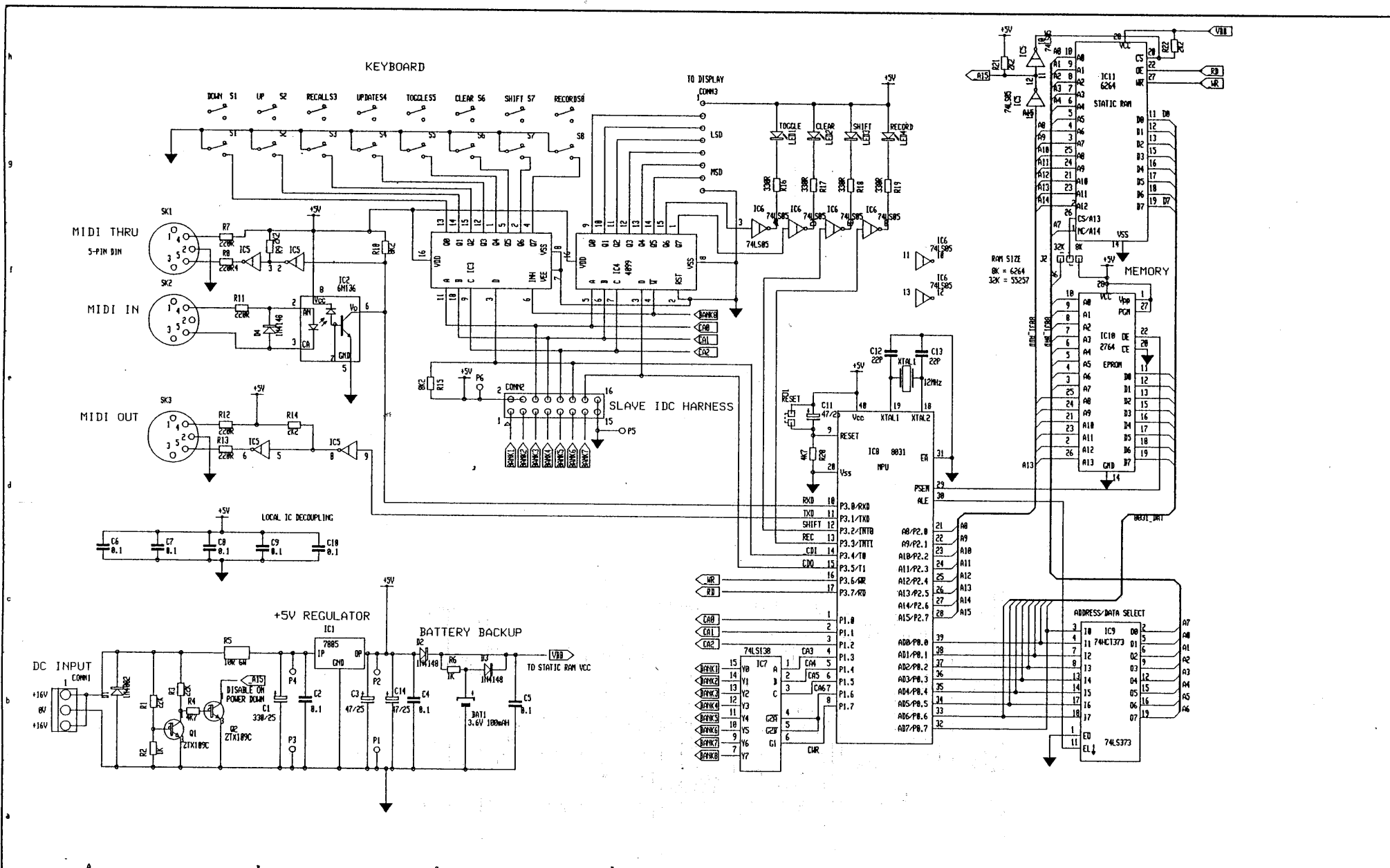

ISS.	REVISION	BY DATE	NOTES	UNIT TITLE	MANUFACTURED IN ENGLAND BY
1	ORIGIN PRODUCTION	CD 29-8-91	1. RESISTORS MARKED # ARE 1% ALL OTHERS ARE 5% 1/4W UNLESS OTHERWISE MARKED 2. ELECTROLYTIC CAPACITORS ARE μ F/VOLTS	S2 MICRO CIRCUIT - MUTE PROCESSOR PCB TYPE AG0305	ALLEN & HEATH FOR THATCHED COTTAGE AUDIO DRAWING No. D088 ISSUE 1

CHANNEL INTERFACE TO IO PCB AG0301 SEE CCT D082

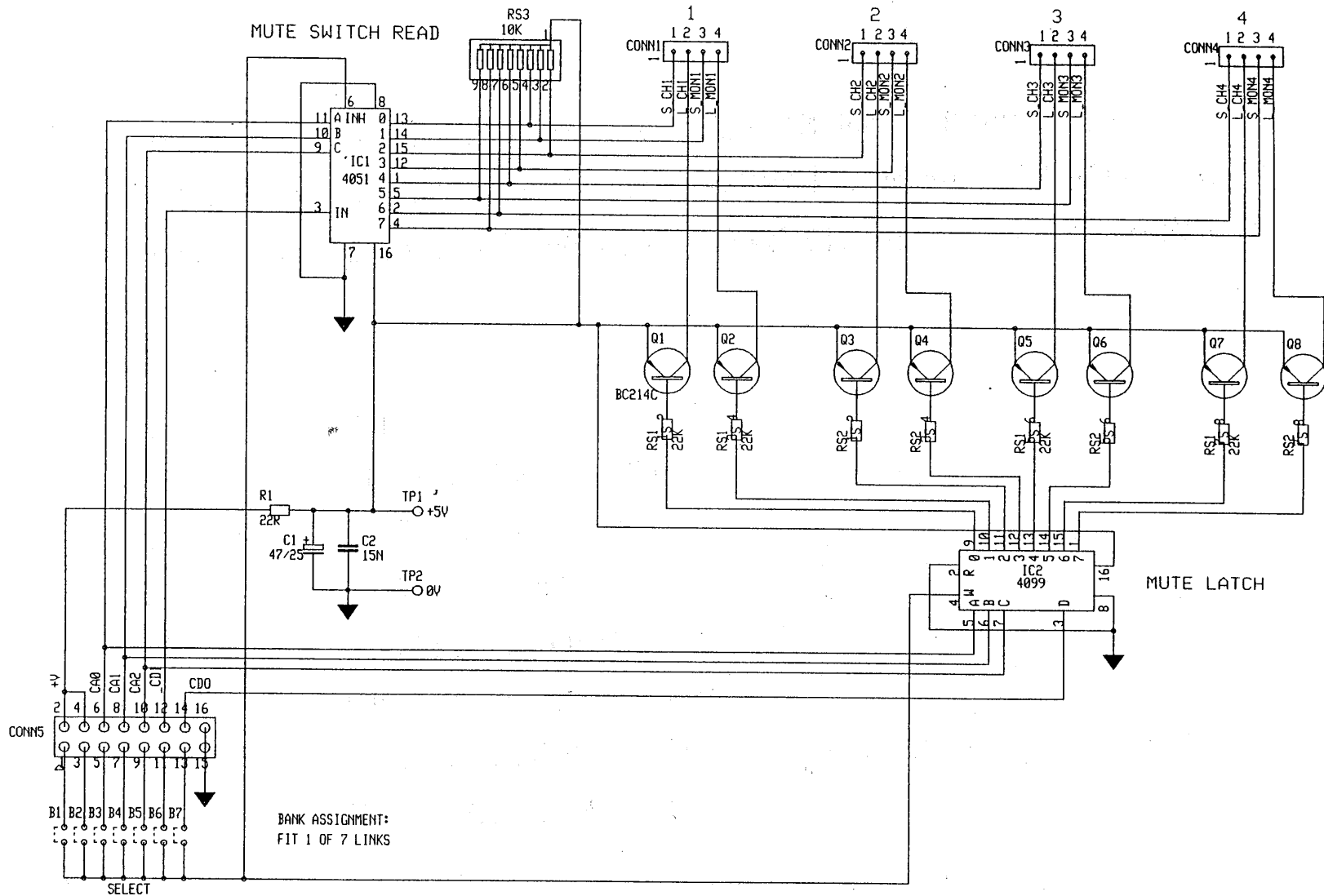

MICRO INTERFACE FROM MICRO PCB AG0305 SEE CCT D088

BANK ASSIGNMENT:
FIT 1 OF 7 LINKS

REVISION	BY	DATE
ORIGIN	PRODUCTION	CD 13-6-91

NOTES

- RESISTORS MARKED * ARE 1% ALL OTHERS ARE 5% 1/4W UNLESS OTHERWISE MARKED
- ELECTROLYTIC CAPACITORS ARE µF/VOLTS

UNIT TITLE
S2

DRAWING TITLE
SLAVE CIRCUIT DIAGRAM
PCB TYPE AG0306

MANUFACTURED IN ENGLAND BY
ALLEN & HEATH
FOR
THATCHED COTTAGE AUDIO
DRAWING No.
D089 ISSUE 1

NOTES FOR THE CONSOLE CHANNEL TO MIDI NOTE NUMBER TRANSLATION TABLE (see overleaf)

KEY

A	-STEINBERG PRO 24
B	-AKAI, YAMAHA, KORG, CUBASE, C-LAB EQUIPMENT
C	-ROLAND EQUIPMENT
I/P	-CONSOLE INPUT
MON	-CONSOLE MONITOR
SR	-STEREO RETURN
RET	-EFFECTS RETURN
AUX	-AUX SEND

NOTES

- CONTROLLER CODE CHANNEL NUMBERS REMAIN THE SAME
- SABER PA CONSOLES, Monitor column 1-8 denotes, PA GROUP (1-8), 9-16, denotes MATRIX (1-8). IGNORE Monitor column 17-24.

THE S2 MIXING CONSOLE

NOTES AND UPDATES

DATE BY DESCRIPTION